

# WOOD DEATH FIRE EJECTION

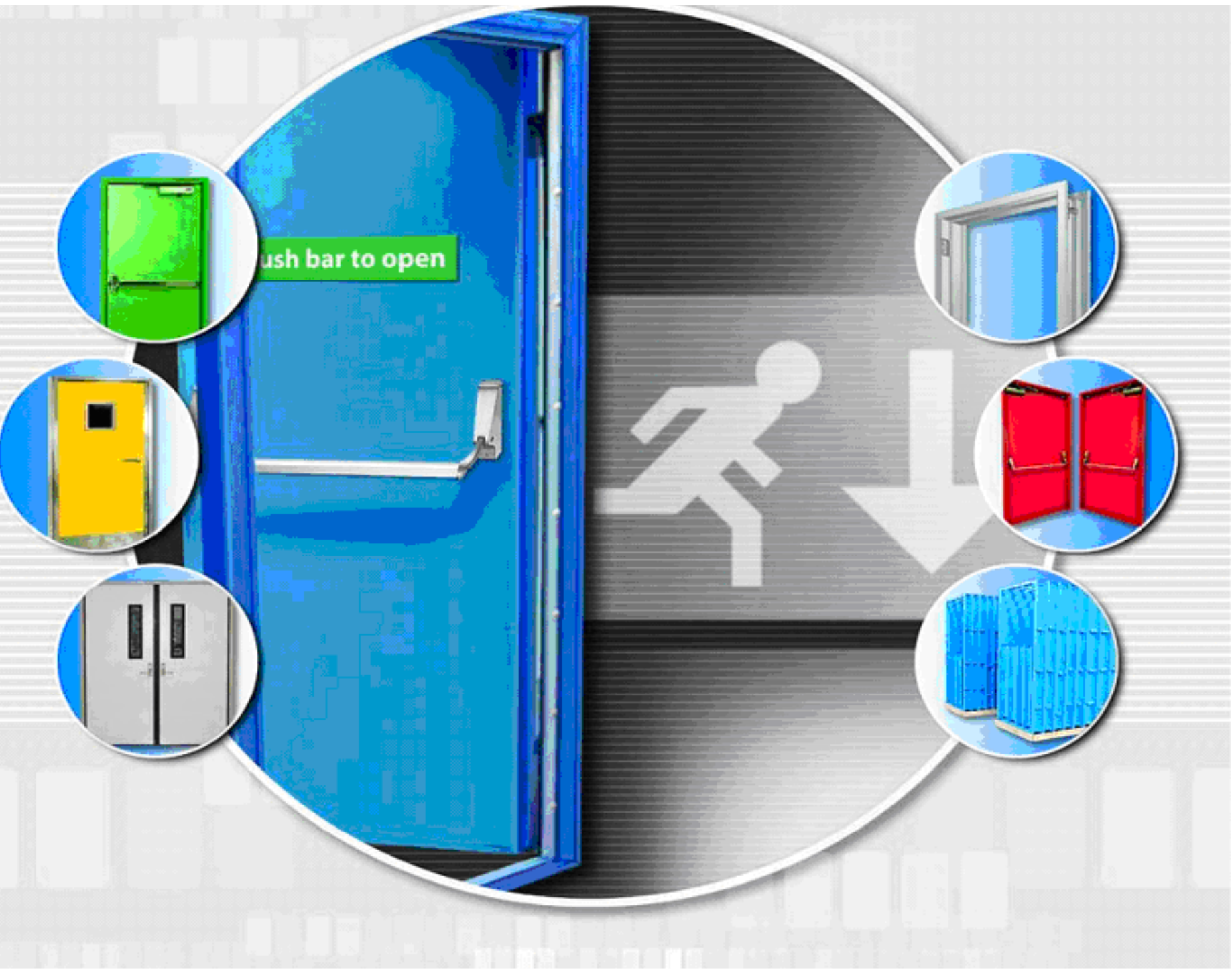

# FIRE DOORS

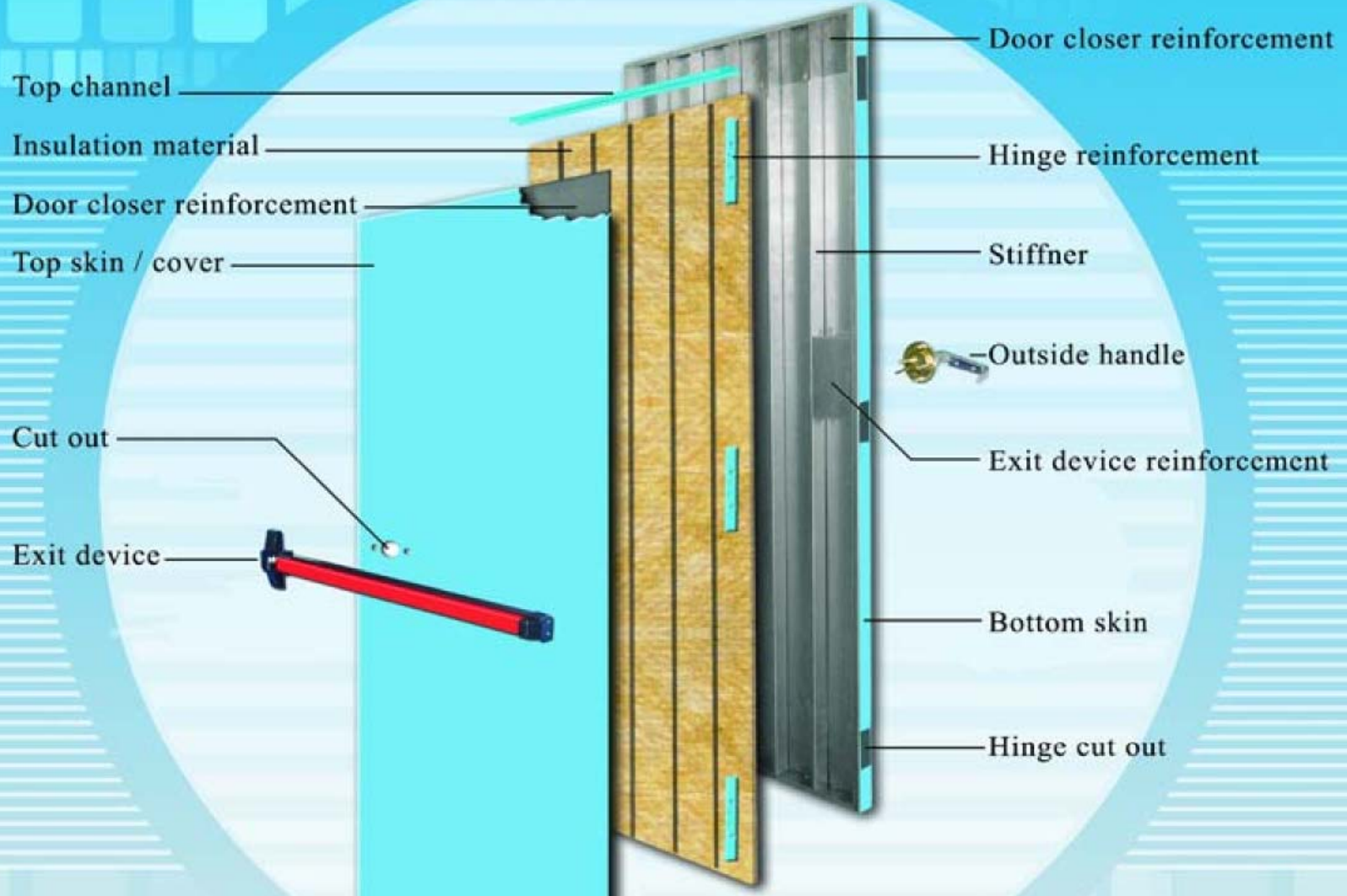

# FIVE MAIN COMPONENTS OF A FIRE RATED OPENING

## FIVE MAIN COMPONENTS OF A FIRE RATED OPENING

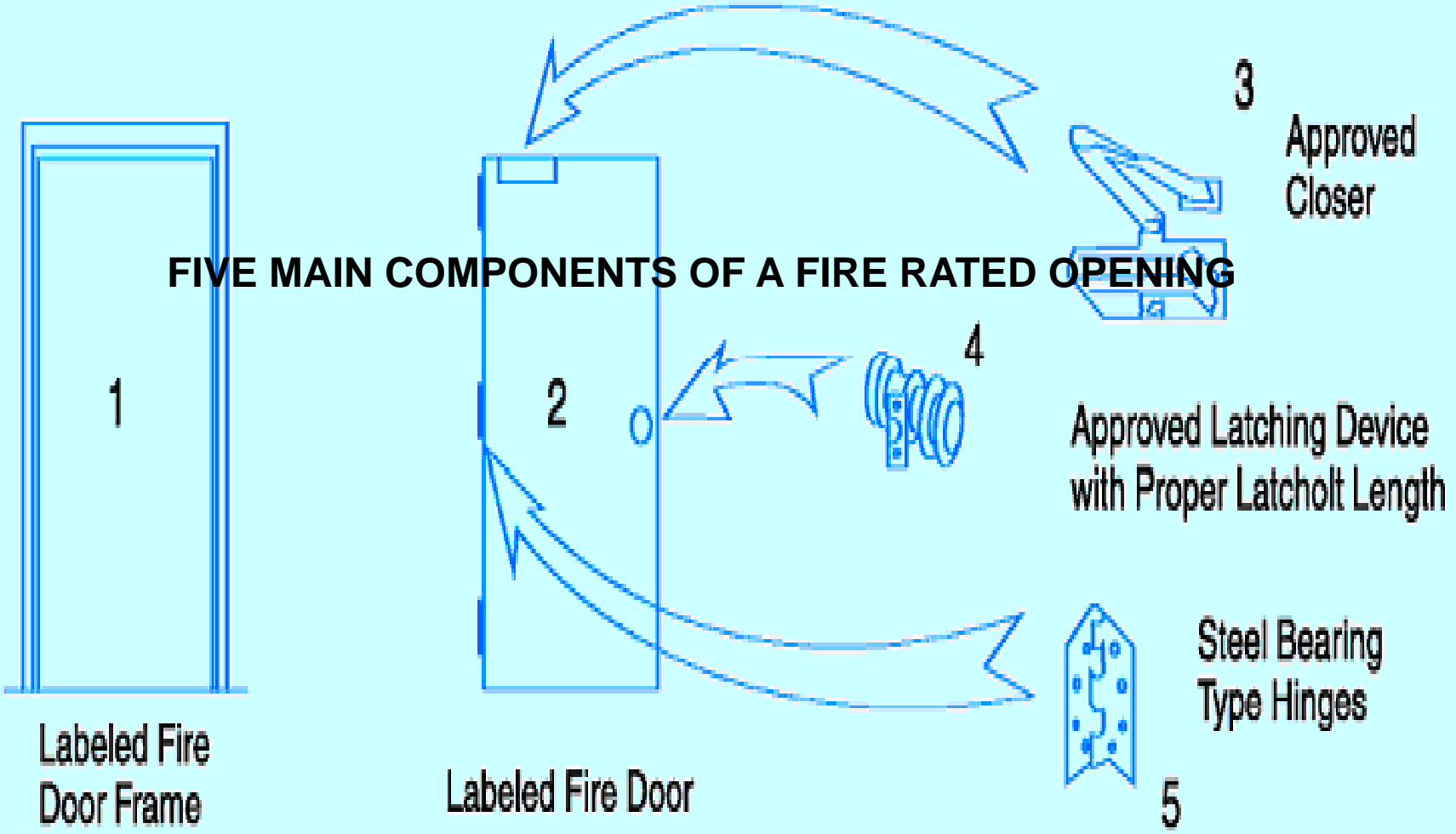

# **GENERAL REQUIREMENTS OF FIRE RATED DOORS AND FRAMES**

## **GENERAL:**

1. Every frame assembly and door leaf must be labeled.
2. Every fire door must have a self close mechanism, unless exempted by code. Doors must also be self latching and remain closed at the time of fire in order to provide barrier against fire.
3. A fire door must be free of any obstruction which could prevent the door from opening properly.
4. Only listed fire door hardware shall be used on a listed door.
5. Fire doors must have steel bearing type hinges.
6. Double doors that require astragals should have at least one overlapping astragal. Double doors with means of double egress shall not be equipped with an astragal that will hinder the free movement of either leaf. A coordinator or open back strike should be used to ensure proper closing.
7. All glazed fire doors must have a steel glazing system. The glass must be labeled wire glass not less than  $\frac{1}{4}$  inches thick.
8. Special glazing material is available for doors with 3 hours fire rating.  
For doors of 1  $\frac{1}{2}$  hour rating, 100 square inches of glass can be used, and for  $\frac{3}{4}$  hours doors, 1296 square inches of glass can be used.

# STANDARD DESIGN OF FIRE RATED DOORS

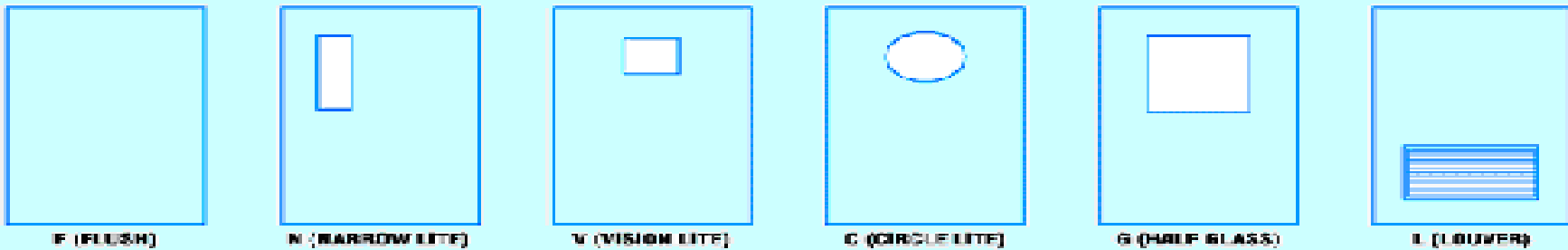

CUSTOM DESIGN (CD). CD is a combination of optional designs applicable for non fire rated doors.

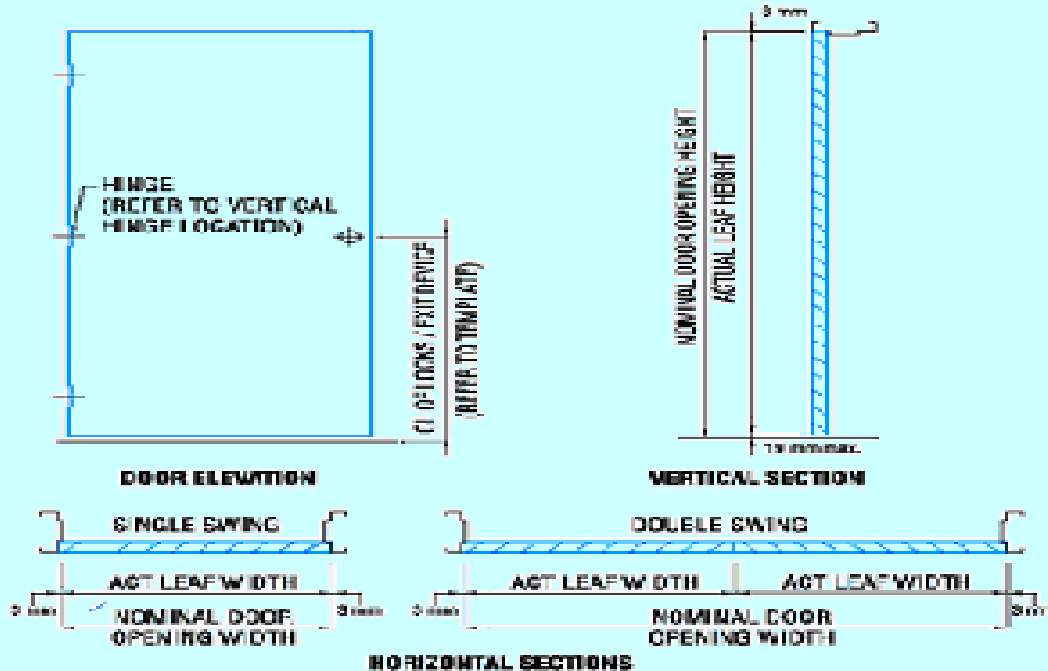
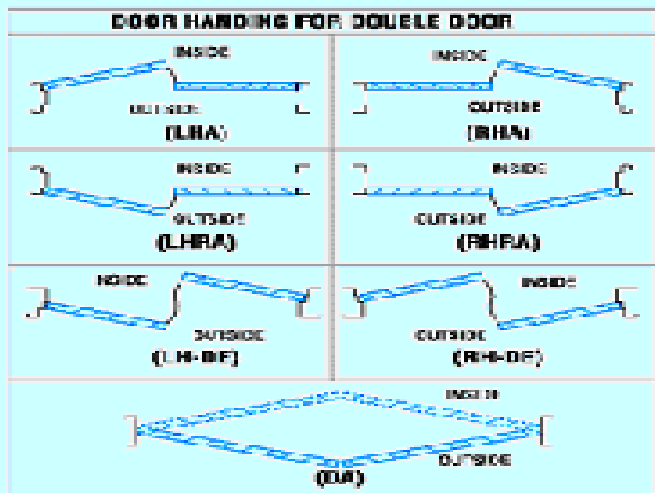
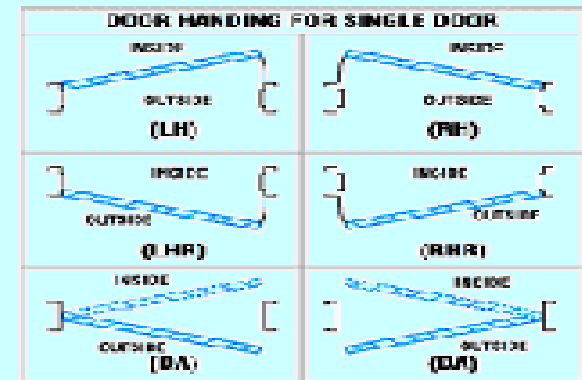
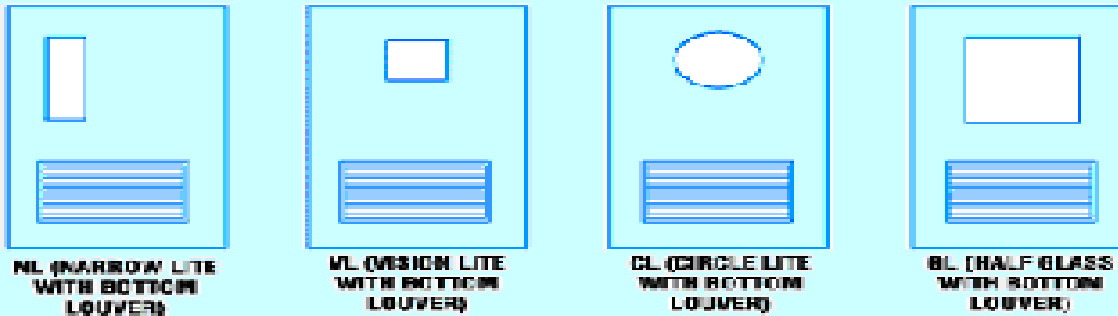

# FIRE DOOR ASSEMBLY (EXPLODED VIEW)

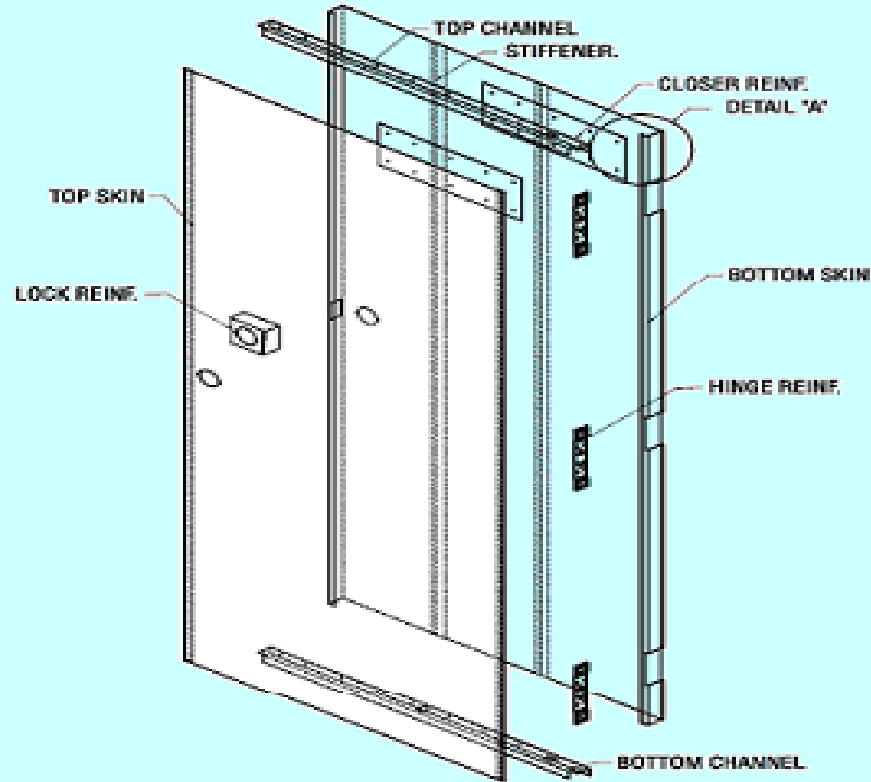

## FOR POLYURETHANE STEEL DOOR (PSD)

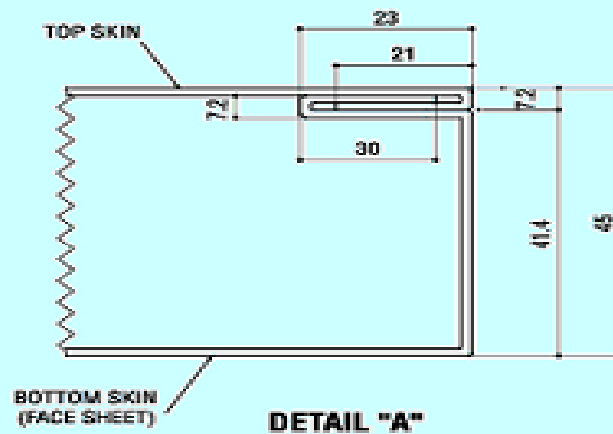

## ROCK WOOL STEEL DOOR (RSD)

### Fire Ratings: Maximum of 2 hours

The RSD model fire doors are made of gauge 16 Cold Rolled Steel, Galvanized Steel, or Stainless Steel. These doors are designed for areas where strength, stability and durability are a priority. Typical applications include entrances to industrial premises, to shops' service doors, to basements, to stair wells and to elevator shafts. They are also widely used as dividing or external doors in electrical and petrochemical plants.

#### **Description**

A vertical door stiffener (thickness ga. 16) is welded across the bottom skin of the door and the top skin is then inserted through a slit and interlocks with bottom skin forming the door leaf. The door is insulated by the rock wool that is inserted along the stiffener with a density of 128 kg/m<sup>3</sup>. The door is held together by top and bottom channels that are 1.5 mm thick each. The interlocked seam along the side of the door provides more durable strength to resist any deformation in the case of fire. The interlocked seam is welded at certain points along the side of the door to prevent failure. The modern machinery and manufacturing methods mean that the leaf has a smooth and even surface.

# DETAIL OF GLAZING

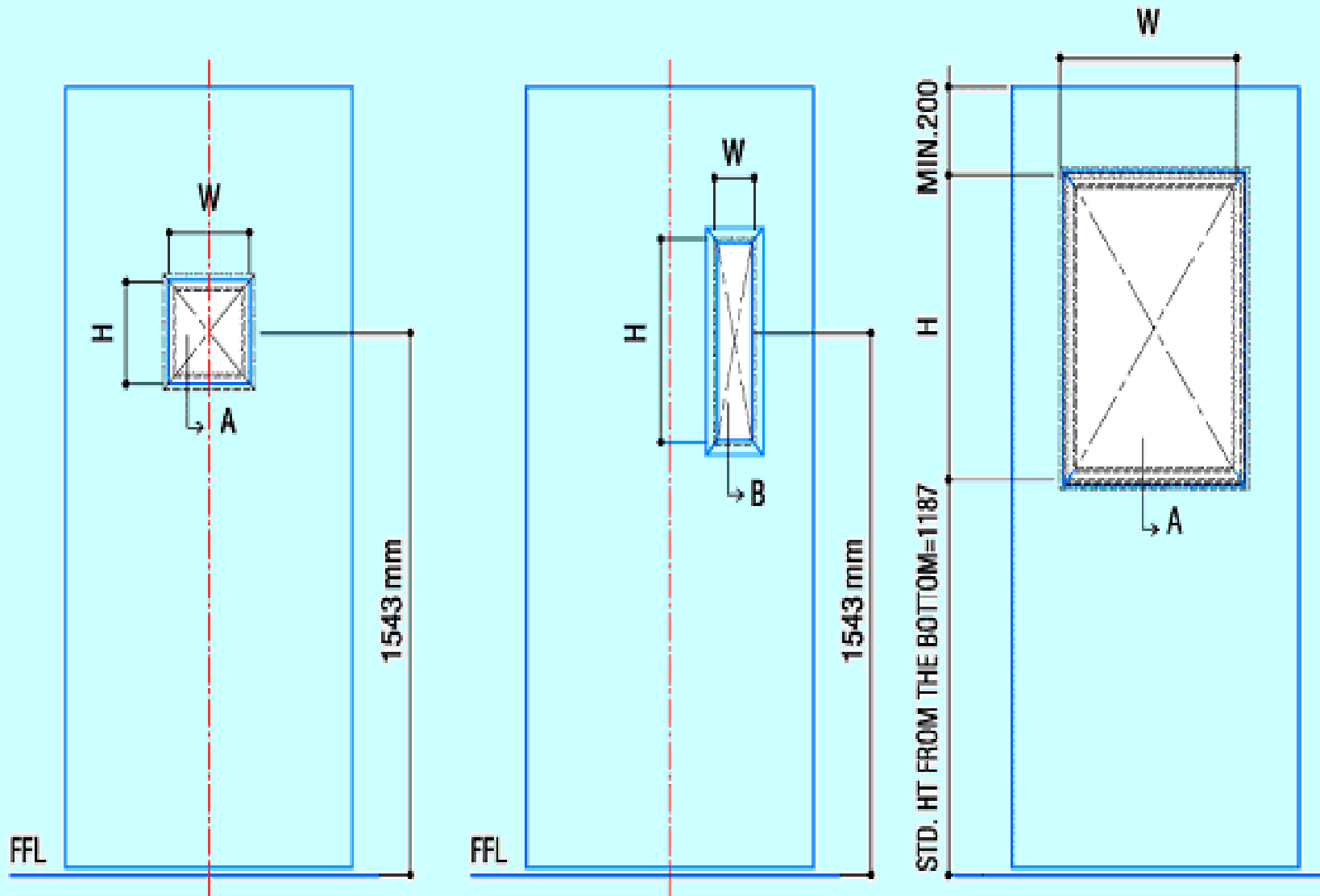

# DETAIL OF GLAZING

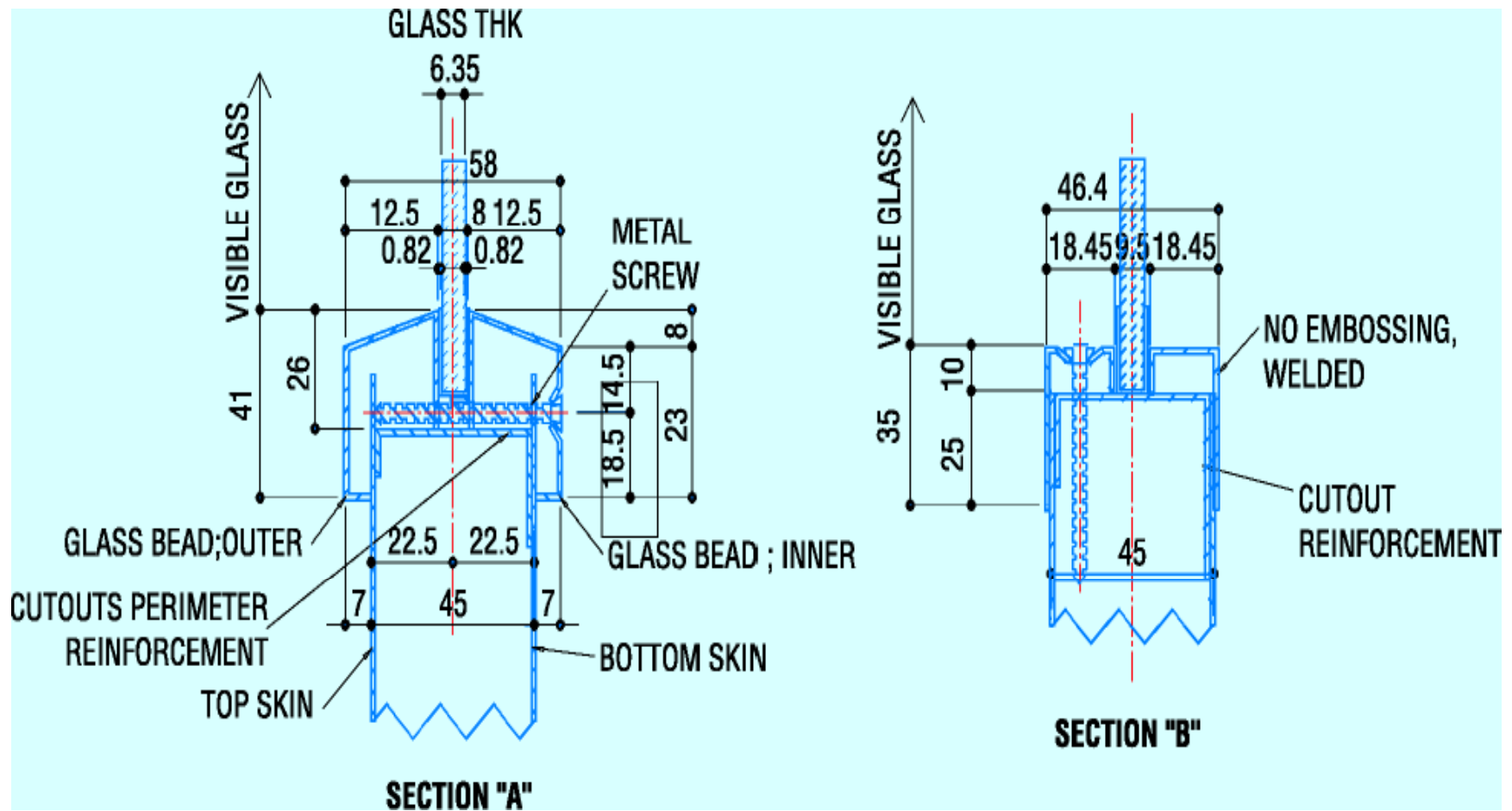

# RSD STANDARD SIZES

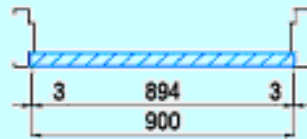
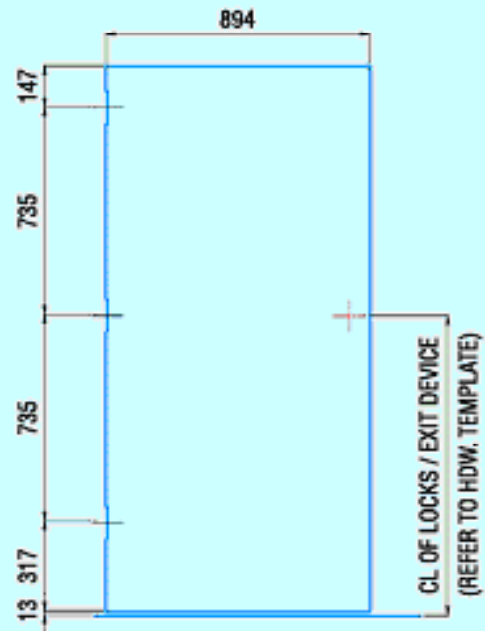

STANDARD DOOR OPENING WIDTH



STANDARD SIZE FOR SINGLE DOOR

# RSD STANDARD SIZES

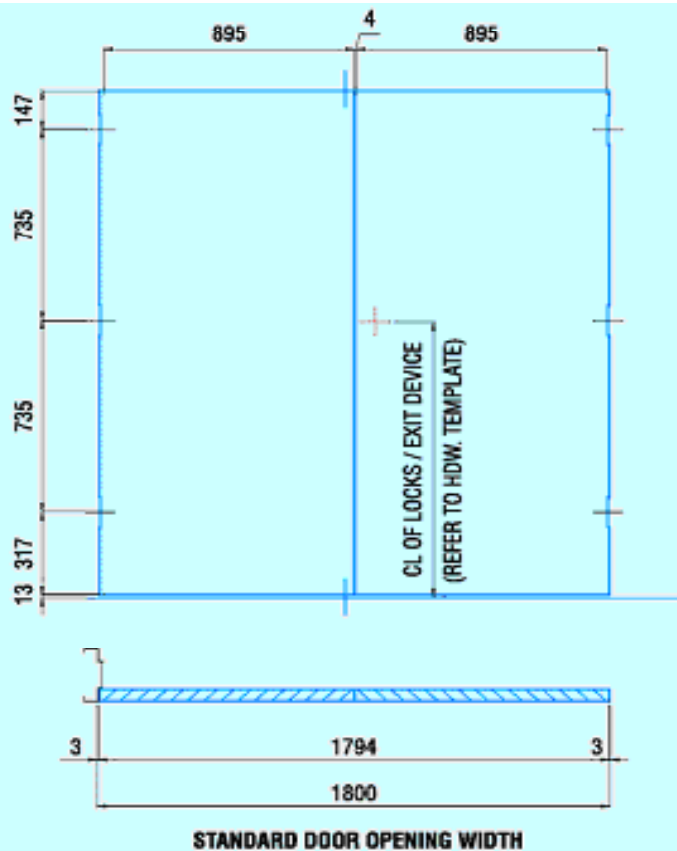

**STANDARD SIZE FOR DOUBLE DOOR**

# FIRE DOOR ASSEMBLY (EXPLODED VIEW)

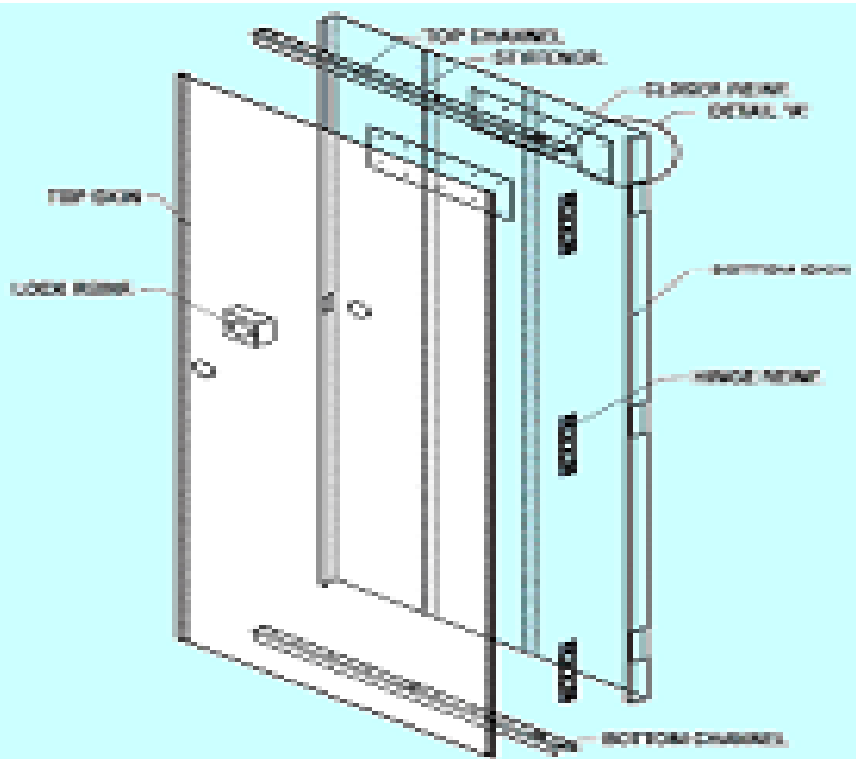

**FOR ROCK WOOL STEEL DOOR (RSD)**

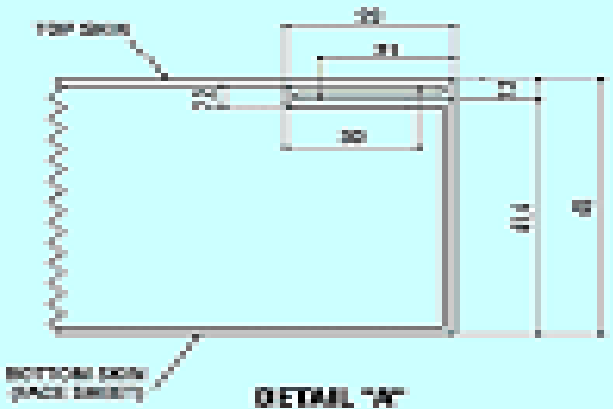

## FIRE DOOR FRAME ASSEMBLY (EXPLODED VIEW)

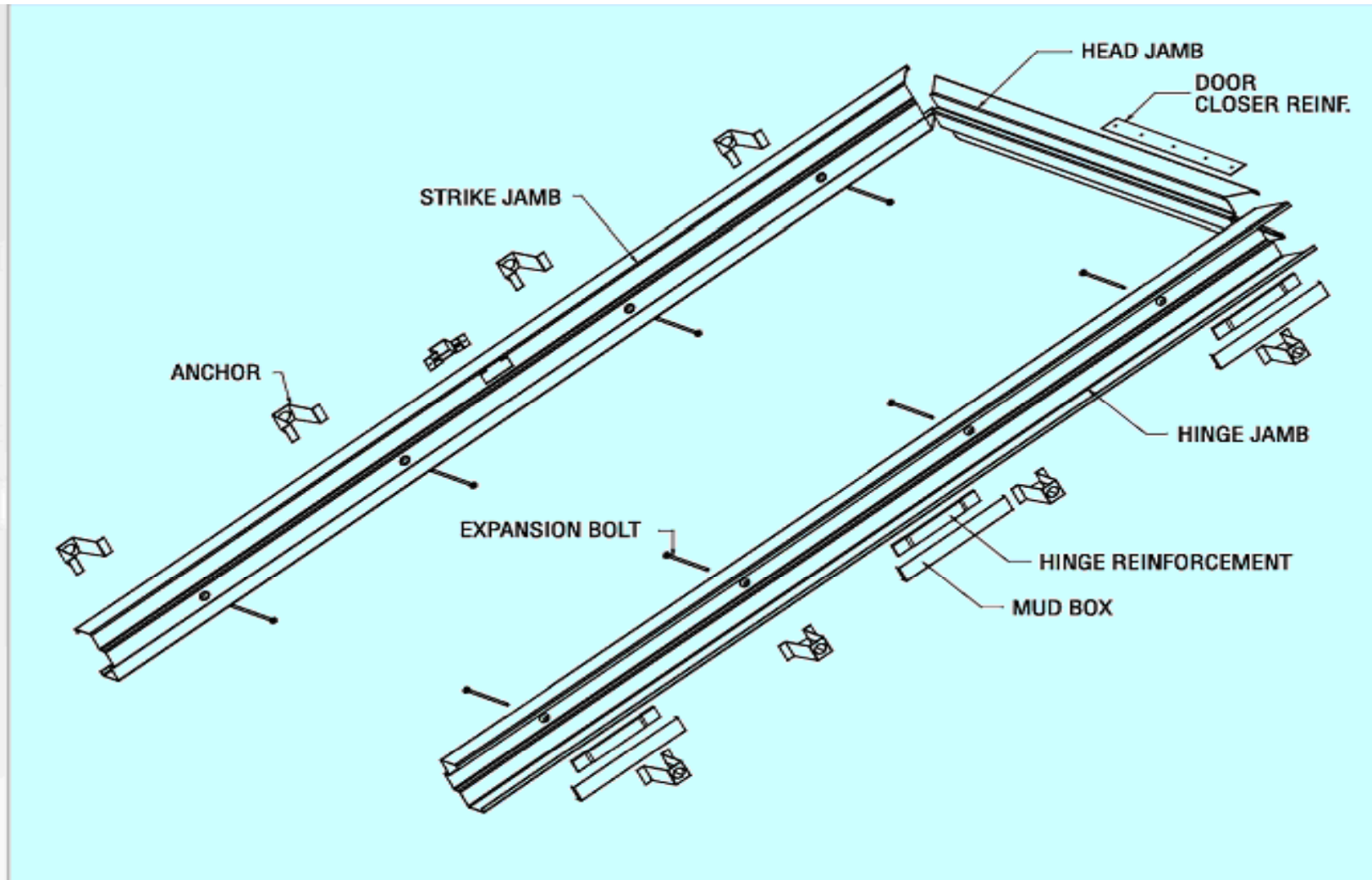

# HARDWARE

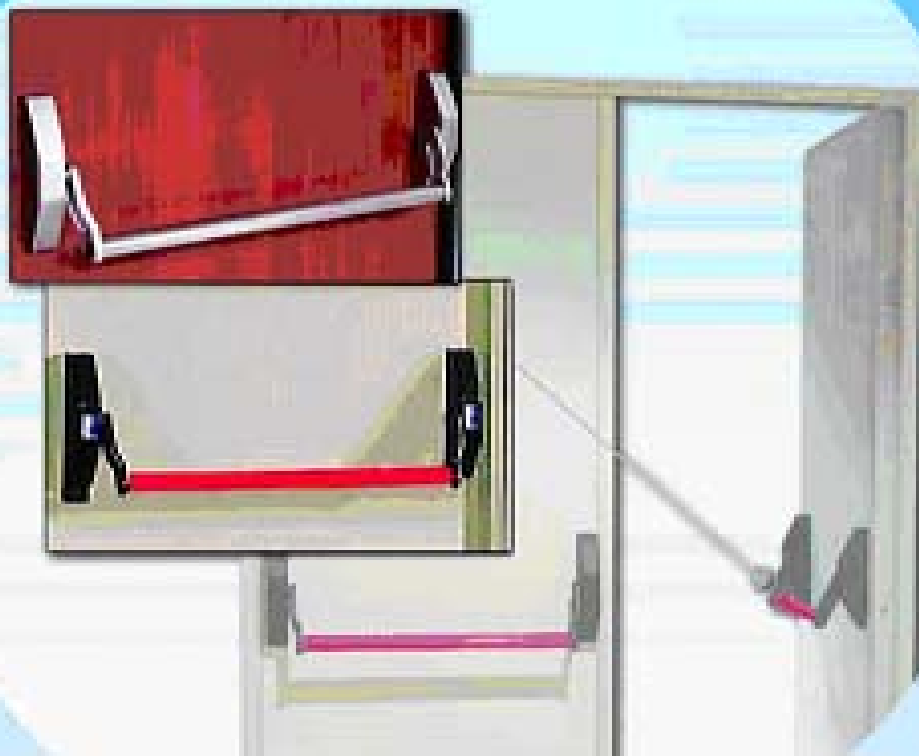

## Description:

Only labeled fire door hardware shall be used and fire certified from approved agency. These include hinges, locks or latches, top and bottom bolts, and door closers. Fire exit hardware consists of exit devices which have been labeled for fire

## HARDWARE FOR SINGLES AND PAIRS OF DOORS

### Hinges (Steel): Butt Type



Full Mortise



Half Mortise



Cylindrical Latch or Lock





Mortise Deadlock

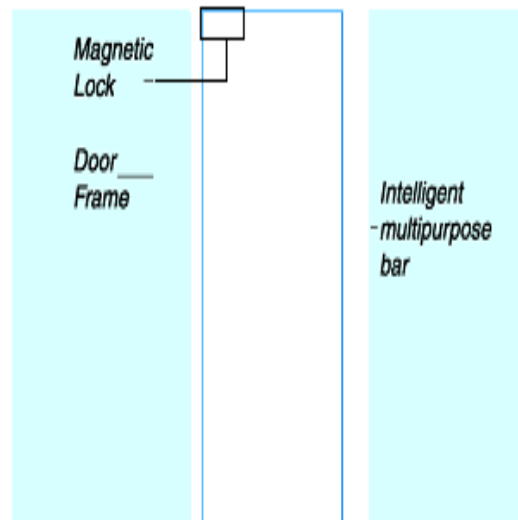

Cylindrical Deadlock



**All single doors and the active leaf  
of all pairs of fire doors are  
permitted to  
have an active latch bolt.**

Closers	
	
Door closer	Floor closer
<ul style="list-style-type: none"> <li>a) Surface Mounted on hinge face of door</li> <li>b) Concealed in door with exposed arm</li> <li>c) Surface mounted on stop of door</li> <li>d) Concealed in head with concealed arm</li> <li>e) Concealed in head with Exposed arm</li> <li>f) Floor mounted for hinged door</li> <li>g) Floor mounted for offset pivoted doors</li> </ul>	

**SOLE DISTRIBUTOR:**

**INFORMATIVE TECHNOLOGIES PAKISTAN**

**Address: 9-A, Block-6 P.E.C.H.S Karachi. Pakistan**

**Phone #: 92-21-345 33 028**

**Fax # : 92-21-345 43 243**